

MGS-G-EU 625-C

MITSUBISHI GAS GENERATOR SET

EU MADE (France)

Quality, reliability, performance, and partnership
- Mitsubishi Heavy Industries Group.

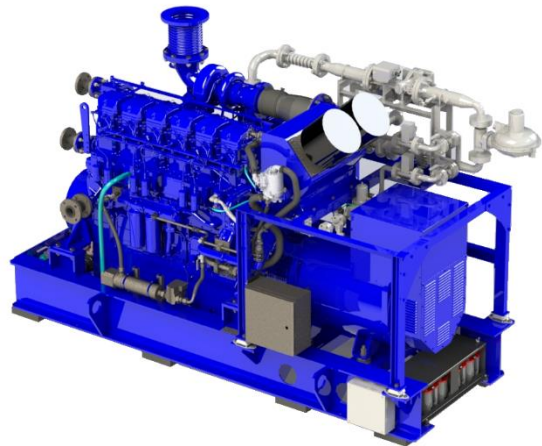

RATING

Generating set model	MGS-G-EU 625-C
Generator voltage	400 V
Frequency	50 Hz
Generator output COP	500 kWe 625 KVA
Power factor – max/min	1/0.8
Duty	Base load
Rating	Continuous
Overload	Not available
Installation location	Indoor

DESIGN CONDITIONS

Ambient temp - avg/max	25/40°C
Ambient temp – min	-15°C
Altitude (maxi)	150 m a.s.l
Relative humidity (maxi)	85%
Fuel oil LHV	36470kJ/kg
Fuel gas	Natural gas
Lube oil consumption – max	0.34 g/kWh
Fuel gas methan number – min	80
Lube oil capacity - max	165 liters
NOx emission level (O ₂ 5%)	500 mg/Nm ³

ALTERNATOR DATA

Enclosed, self ventilated, self-regulated, brushless	
Bearing configuration	Single
Insulation class	H
Temperature rise class	F
Cooling method	Air IC01
Protection	IP23
Excitation system	Digital
PT100 for bearing and stator winding	
AVR for single and parallel operation	
Space heater	
Set of CT's for measure or protection	

ENGINE DATA

Engine model	GS6R2-PTK
Engine speed	1500 Rpm
Engine brake output	523.6 kWm
Cylinder configuration	6 L
Total displacement	30 liters
Bore x Stroke	170 x 220 mm
Compression ratio	12.6:1
Turbocharged	4 cycles
Governor	Electronic
Cooling method (electric pump)	Water (loose radiator)
Starting method	Electrical 24 V DC
Gas pressure at gas line inlet	300 to 500 Kpa

CE COMPLIANCE

2006/42/EC : machinery

LANGUAGE – UNITS

Drawings, documents, nameplates in English

SI metric system

PERFORMANCES @ COP (LV : 400V)

Auxiliary consumption (Cooling & ventilation) avg/max	10/15 kWe
Step up transformer losses	-
Gross generator output	500 kWe
Fuel gas input	1163 kW
Fuel gas flow rate	115 Nm ³ /h
Electrical efficiency	43%
Exhaust gas temperature	415°C
Exhaust gas flow rate	2288 Nm ³ /h
Air intake flow rate	42 m ³ /min
Noise level@ 1m - max	109 dB (A)

HEAT BALANCE

Heat rejection on Jacket water, HT circuit (recoverable)	258 kW
Heat rejection on lube oil and charge air, LT circuit (not recoverable)	47 kW
Heat rejection on exhaust (at 120°C)	260 kW
Thermal radiation (engine block)	36 kW
Thermal efficiency	44.5 %
Flow rate of HT cooling circuit	39.6 m ³ /h
Flow rate of LT cooling circuit	10 m ³ /h
Cooling water temperature at HT outlet – max	91°C +/-2
Cooling temperature at LT inlet – Avg / max	35/49 °C

TOLERANCES AND CONDITIONS

Efficiency data for average conditions (avg) – derating above 150 m asl or 40°C intake air temperature

Fuel input: 0/+5% (ISO3046/1). Submitted to fuel gas specification confirmation

Heat rejection data: 12 % .Add 17 % for radiator design

Exhaust gas flow / temperature: +/- 6% - +/- 8%

Pictures are not contractual and may include optional accessories

These data are not contractual. They can be modified by MTEE without prior notice

STANDARDS

I.S.O. : International Standard Organization

C.E.N. : European Standard Committee

I.E.C: International Electric Commission

J.I.S : Japanese Industrial Standards (for engine)

J.E.C: Japan. Electrotechnical committee (engine)

J.E.M: Japan Elec. Manufacturers Association (Eng.)

Manufacturers standards

GENERATOR SET EMBEDDED CONTROL PANEL

Manual start and stop by push buttons on the (AGC) Automatic Genset Controller (DEIF made)

Automatic start and stop sequence

Automatic engine protection

Manual and automatic synchronization and parallel operation of gensets

Manual and automatic load sharing of generating sets

Automatic start and stop according to increase or decrease of load demand

Automatic control of engine auxiliaries and power supply:

- Jacket water pump
- Intercooler water pump
- Jacket water heater
- Alternator space heater
- Lube oil priming pump
- Radiator cooling fan
- Temperature control valves for jacket water and inter cooler
- Genset's enclosure ventilation fans

24 V DC energy block to supply PLC and panel equipment

24 V DC charger to supply engine starting batteries

7" Human Machine Interface (HMI) for display and monitoring of operating data, alarms and history logs

Harness assembly for cable connection of control panel to genset

HMI is equipped with Ethernet TCP/IP com port for internet remote access

Generating set protection and alarm devices

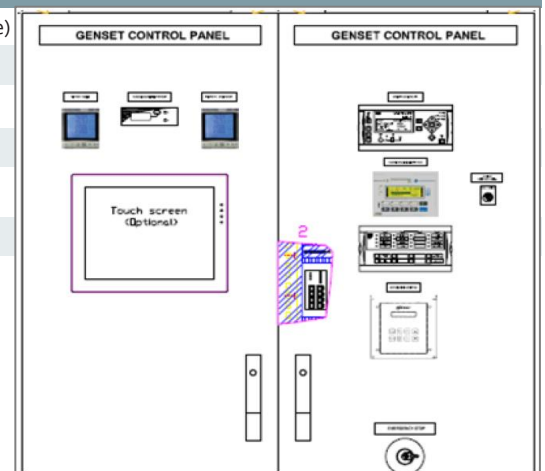

MGS-G-EU 625 GENSET (GS6R2 - PTK / ECO40 - 2L/4) LAYOUT

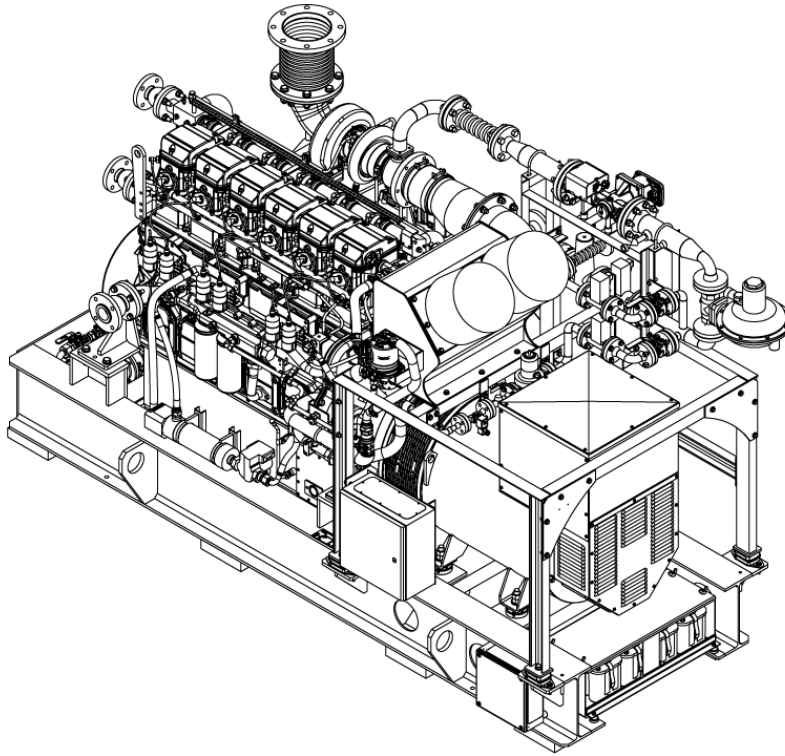

Dry Weight = 5690Kg

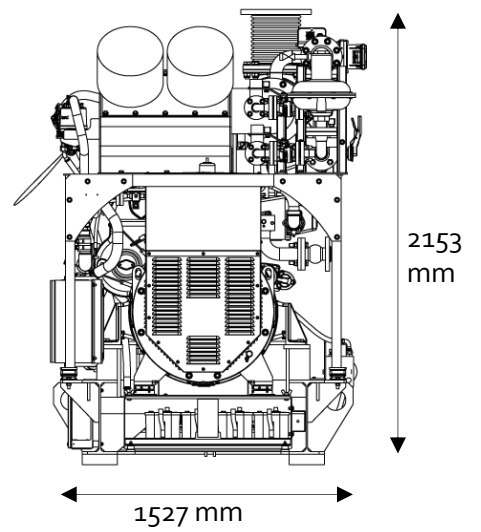
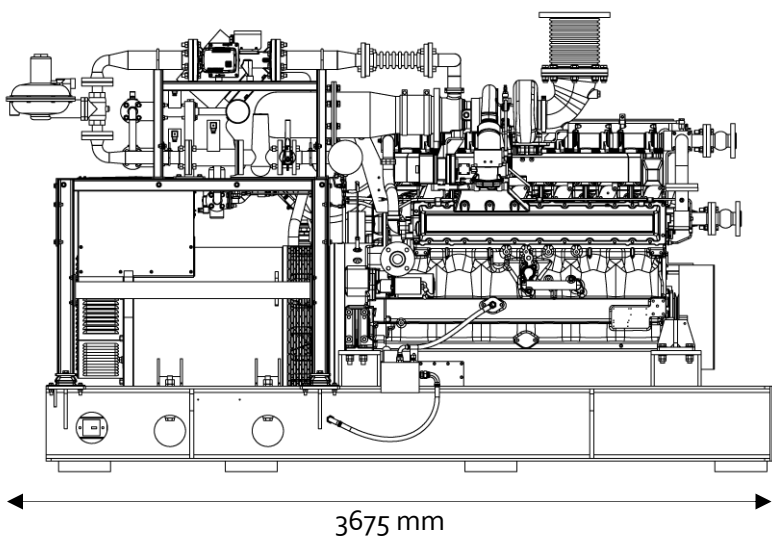

SCOPE OF SUPPLY

- Standard item
- Option
- Not included or not applicable

	Open skid set		Containerized set	
	LV	HV	LV	HV
Steel base frame with engine-alternator	●	-	●	-
Elastic suspensions of the generating set	●	-	●	-
Starting batteries and cables	●	-	●	-
Pump for lube oil priming	●	-	●	-
Jacket water heating + alternator heating	●	-	●	-
Fuel main and pre chamber gas train fitted on generating set	●	-	●	-
Oil mist separator	●	-	●	-
Dry air filter, high efficiency on turbocharger	●	-	●	-
Electrical jacket water pump (loose supply for open skid)	○	-	●	-
Electrical Intercooler pump (loose supply for open skid)	○	-	●	-
Remote external dry air cooler	○	-	●	-
Temp. control valve for jacket water (loose supply for open skid)	●	-	●	-
Temp. control valve for Inter cooler (loose supply for open skid)	●	-	●	-
Remote box for radiator fan (feeders and meter)	○	-	●	-
Generating set remote control panel (GCP)	●	-	●	-
Harness assembly for GCP with connectors (mounted on genset side)	●	-	●	-
Remote Generating set protection Circuit Breaker (LV, HV)	○	-	●	-
Generating set factory tests (standard program)	●	-	●	-
Generating set finishing color: Blue RAL 5010	●	-	●	-
Exhaust silencer 30 to 50 dB(A) attenuation (loose supply for open skid)	○	-	●	-
Exhaust bellow on turbocharger outlet	●	-	●	-
Automatic filling device on engine sump	●	-	●	-
Lube oil service tank 200 liter capacity (loose supply for open skid)	○	-	●	-
Set of flexible connections for engine	●	-	●	-
Engine standard tools for routine maintenance	●	-	●	-
Step up transformer LV / HV 10 to 20 kV	-	-	-	-
LV connection busbar from alternator to transformer	-	-	-	-
Sound proofed generating set container	-	-	●	-
Elbow pipe between the engine and the silencer	-	-	●	-
Water pipes from engine to dry air cooler	-	-	●	-
Cooling circuit degassing and priming pipes	-	-	●	-
Lube oil pipes from service tank to engine sump filling device	-	-	●	-
LV cables from alternator to protection circuit breaker	-	-	●	-
HV cables from transformer to protection circuit breaker	-	-	-	-
Fuel gas flow meter fitted on gas train	○	-	○	-
Scada system, Integrated in genset control panel (15" touch screen)	○	-	○	-
Gas compressor for pre chamber gas train in case of site low press	○	-	○	-
Oversized dry air cooler for high ambient temp	○	-	○	-
CHP hot water production module 70/90°C	○	-	○	-
Thermal metering	○	-	○	-
On site assistance for supervisory, commissioning and training	○	-	○	-
Alternator according to specific country grid code	○	-	○	-

CONTACTS DETAILS

MITSUBISHI TURBOCHARGER AND ENGINE EUROPE B.V.
 70 rue Jean Jaurès
 59 770 MARLY
 France
 Phone: + 33 3 27 32 48 48 Fax: + 33 3 27 32 48 49
 e-mail : mteef@mtee.eu
 Web : www.mtee.eu

[Space for stamp with Dealer contact information]

More information

Contact your local Mitsubishi Engine & Energy dealer for more information regarding Mitsubishi Generator Sets and optional equipment.
 Or visit www.mtee.eu